

OTHER PRODUCTS INFORMATION

PDC100



The NHN PDC-100W pivot closers are suitable for timber, aluminium and steel doors.

Incorporating the latest cam type technology, the NHN PDC-100W pivot closers offer easy opening with increased efficiency on the closing torque.

The closing speed is easily adjusted via two independent adjustment valves.

Available with or without hold open at 90°.

Narrow style with high performance.

Easy installation; costs and time saving as no preparation on the floor needed.

5 year Guarantee against faulty workmanship.

CONCEALED DOOR CLOSER



Features

1. With the door closed, the main body and lever are concealed to streamline the external appearance....available for standard and reverse-installation closers.
2. The super-thin main body can be installed even on thin doors....aluminum doors, standard steel doors, wooden doors, etc.
3. The refined design, providing smooth opening and closing, is ideal for reception rooms, hotel rooms, libraries, etc....closing speed and the hold-open angle can be easily adjusted.
4. Functional, durable, and attractive....a needle bearing smoothly operates the stylish closer.

**NH** 80V SERIES

**CE** Tested to EN1154 and fire tested to EN1634-1



The New NHN 80V Series offers a comprehensive range of hydraulic, power adjustable door closers to suit all applications.

The New NHN 80V Series of door closers incorporates the latest engineering technology to provide three power adjustable (by allen key) door closers. Successfully awarded EN1154, EN1634-1 and CE Certifications, the NHN 80V Series is backed up with a 10 years 'No Quibble' guarantee.

FEATURES

- 83V for sizes 2-4, 85V for sizes 4-6 and a heavy duty 87V for sizes 6 & 7. See the selection chart below for the full range and applications.
- Backcheck and delayed action functions available.
- Easy installation and adjustment.
- Comprehensive range of accessories
- Slimline body.
- Non-handed.

SELECTION CHART

Power size (EN)	Max. door width (mm)	Max. door weight (kg)	83V SERIES						85V SERIES						87V SERIES							
			REGULAR	HOLD OPEN	BACK CHECK	DELAYED	SLIDE ARM	PARALLEL	REGULAR	HOLD OPEN	BACK CHECK	DELAYED	SLIDE ARM	PARALLEL	REGULAR	HOLD OPEN	BACK CHECK	DELAYED	SLIDE ARM	PARALLEL		
2	850	40					83V-GL	83VP														
3	950	60	83V	183V	83V-BC	83V-DA																
4	1100	80										85V-GL	85V-P									
5	1250	100							85V	185V	85V-BC	85V-DA										
6	1400	120																87V	187V	87V-BC	87V-DA	
7	1600	140																			87VP	87VP



TOWER WEST 12FL, UMEDA SKY BUILDING, 1-1-30, OYODO-NAKA, KITA-KU, OSAKA 531-0076 JAPAN

Phone: 81-(0)6-6454-9721

Facsimile: 81-(0)6-6454-9726

E-Mail: info@kenwa.co.jp http://www.kenwa.co.jp

http://www.micomautodoor.com

E.&O.E.

All sizes, photo's and drawings are subject to change without prior notice. Copyright © 2010 KENWA CO.,LTD. OSAKA JAPAN All Rights Reserved.

DISTRIBUTED BY

FUNCTION

Latching function (standard)

This function accelerates the door in the final 2° of closing, in order to overcome any resistance such as seals, latch bolts etc. This provides a secure and complete closure of the door.

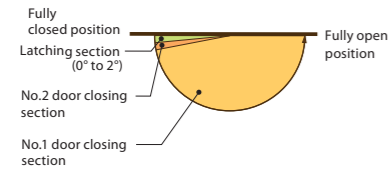

Back-check function (optional)

This function is built into the door closer body and checks the outward swing of the door. Most suited where the opening door might hit a wall i.e. in a corridor, or where it could injure someone if opened too quickly. It is recommended for use on externally opening doors in windy environments. The backcheck function works between 70° & 85°. The backcheck strength can be adjusted by turning the backcheck valve screw located on the end of the closer body. IT SHOULD NOT BE REGARDED AS A DOOR STOP!

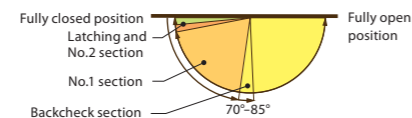

Delayed door closing function (optional)

This function reduces the closing speed of the door to allow passers-by sufficient time to pass through the door opening i.e. people in wheelchairs, hospital staff with beds, elderly people etc. The maximum delay of 90 seconds is achieved from the 180° (the fully open angle) thru to 85°. After which the normal closing process takes effect to provide a secure and complete closure of the door. The duration of the delay can be adjusted via the delayed valve screw located next to the spindle.

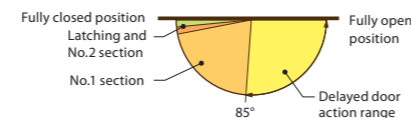

ADJUSTMENT

Force adjustment

Installation "A" Decreases the closing force by about 10% for the first 4° of opening and final 4° of closing.

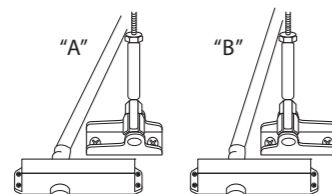

Installation "B" Increases the closing force by about 10% for the first 4° of opening and final 4° of closing.

Latching angle adjustment

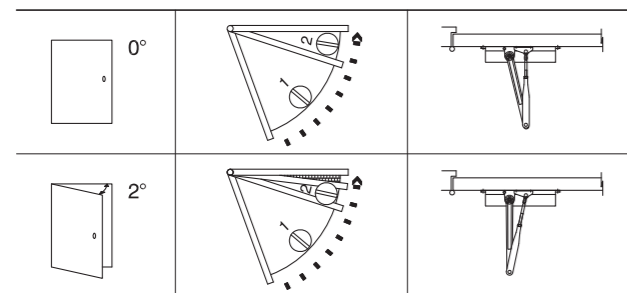

Spring power adjustment

Turn the 'Power Adjusting Screw' the required number of clockwise or anti-clockwise turns according to the door width as indicated in the chart. In adverse weather conditions, increase the number of turns as required.

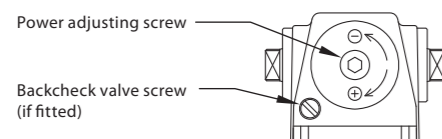

	Size (EN)	No. of turns	Direction	Max. opening angle
83V	2	6	-	180°
	3	0	*	180°
	4	3	+	180°
85V Fixing Position 1	3	0	*	180°
	4	1	+	180°
85V Fixing Position 2	5	0	*	180°
	6	4	+	130°
87V	6	5	-	130°
	7	0	*	130°

\*Pre-set size at factory

NHN FUSIBLE LINK FOR No.80V SERIES

The fusible link is a mechanical device, which can be installed on the standard hold-open arms of the NHN no. 80V series. The door closers fitted with the fusible link can be used on fire doors, which are normally kept open in the hold-open position. In case the fuse element reaches the temperature of 58° C. it will fall apart and the door will be closed by the door closer.

Please ensure yourselves if the use of the fusible link is accepted by the local fire authorities.

INSTALLATION METHOD.

The fusible link is a mechanical device, which can be installed on the hold-open arms of the NHN door closers.

The fuse element is available in 5 grades, namely (58°, 68°, 74°, 100°, 138° and 176° C) In case the fuse element reaches its maximum temperature, it will melt and fall apart; this will release the door from its hold-open position and the door closer will close the door. Ideally in situations where electricity is not available. Please check always with the local authorities if application of the fusible link is allowed and ask for their written approval.

The installation of the fusible link is easy. The regular bolt of the hold-open arm at the pivot point has to be removed. Fit the fusible link on the pivot point of the hold-open arm with the supplied washers and bolt illustrated. Determine the required hold open position, ensure that the serrations interlock each other and tighten the bolt firmly with a spanner. Do not overtight as it might damage the fusible link.

Remark: The use of fusible link is only possible with the regular hold-open arm applications, NOT in parallel arm applications.

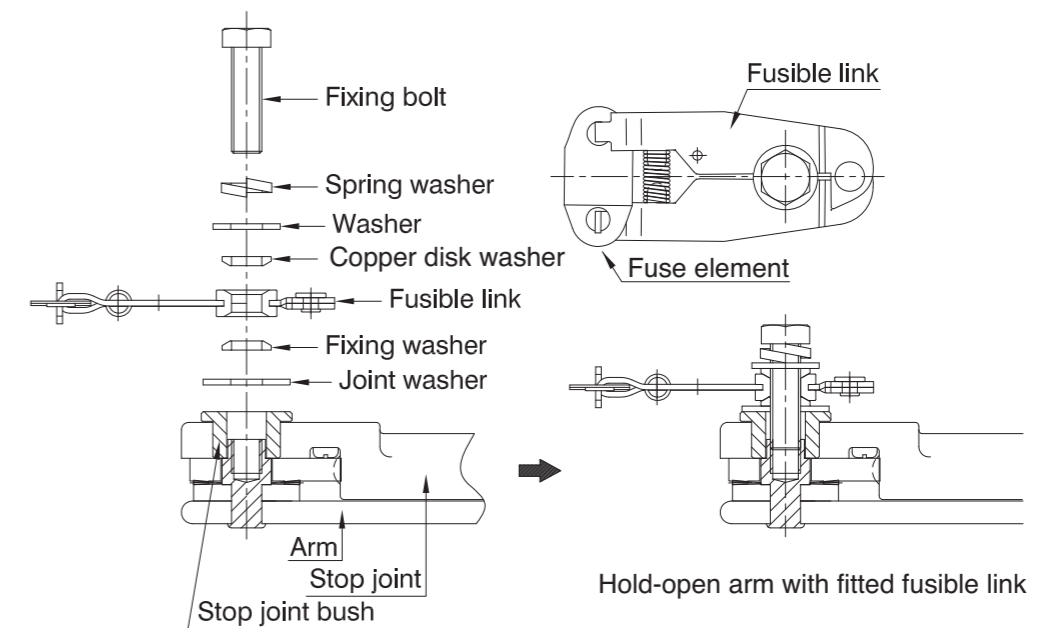

No.	°F	°C
315155	155°	68°
315165	165°	74°
315212	212°	100°
315280	280°	138°
315350	350°	176°

INSTALLATION

Standard installation

Closer mounted on pull side of the door

This illustration shows right hand configuration (DIN L)

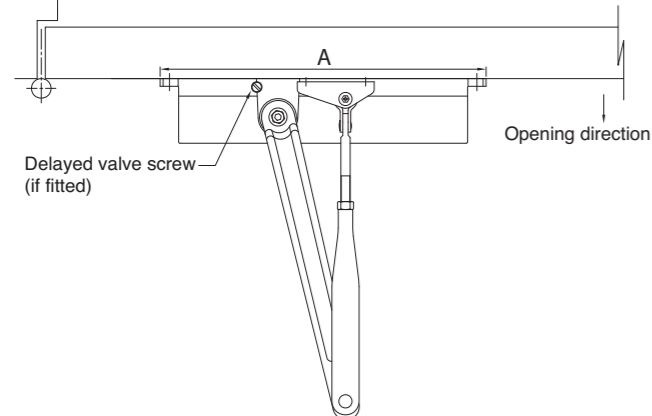

TYPE	A	B	C	D	E	F
83V	246	200	97	232	49	49
85V Fixing Position 1	282	210	55	268	55	52
85V Fixing Position 2	282	210	90	268	55	52
87V	282	210	90	268	55	52

(Unit: mm)

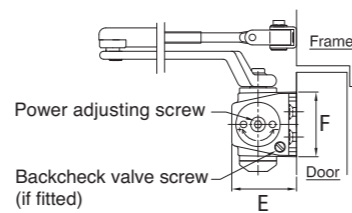
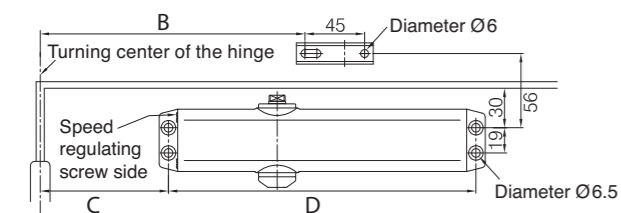

Top jamb installation

Closer transom mounted on the push side of the door

This illustration shows left hand configuration (DIN R). Opening direction

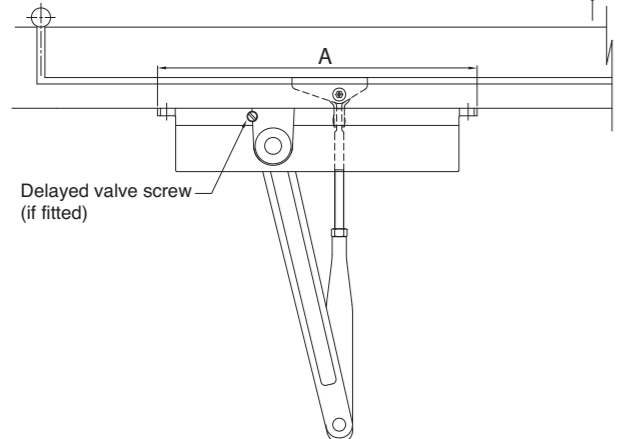

TYPE	A	B	C	D	E	F
83V	246	97	232	200	49	49
85V Fixing Position 1	282	55	268	210	55	52
85V Fixing Position 2	282	90	268	210	55	52
87V	282	55	268	210	55	52

(Unit: mm)

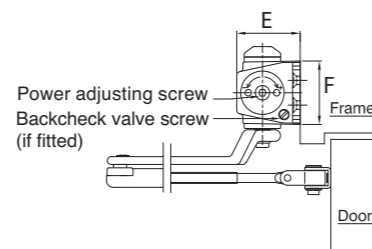
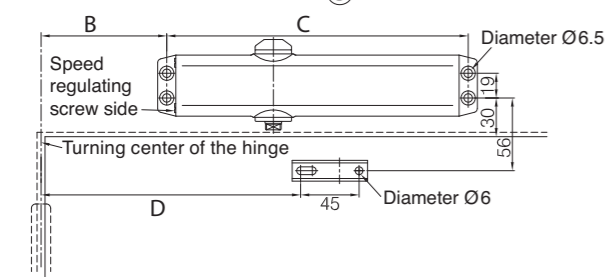

INSTALLATION

Slide arm installation

This illustration shows right hand configuration (DIN L).

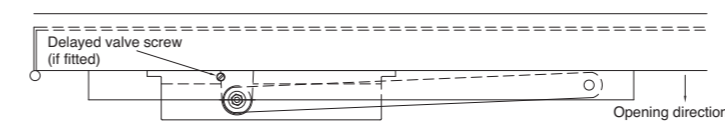

TYPE	A	B	C	D
83V	118	232	49	49
85V · 87V	108	268	55	52

(Unit: mm)

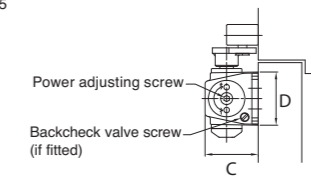
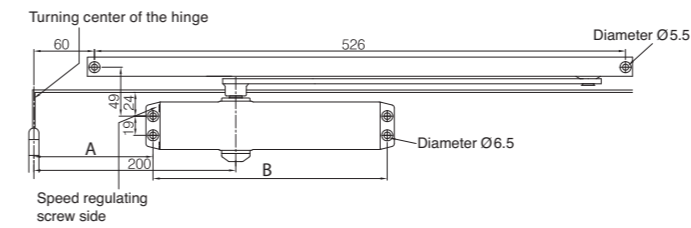

Slide arm installation (Out-swing)

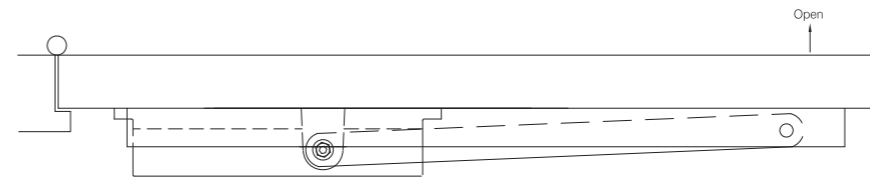

TYPE	A	B	C	D
?	32	232	49	49
?	17	268	55	52

(Unit: mm)

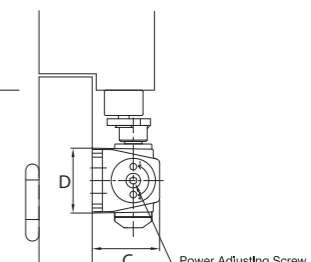
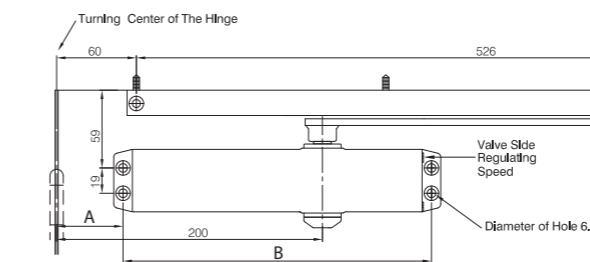

Slide arm installation (Top jamb)

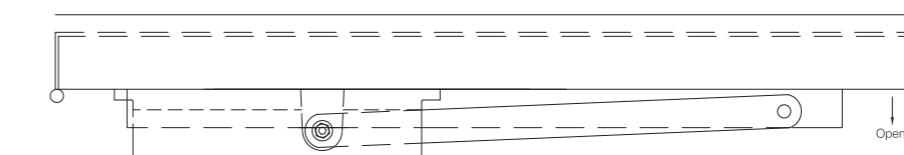

TYPE	A	B	C	D
?	32	232	49	49
?	17	268	55	52

(Unit: mm)

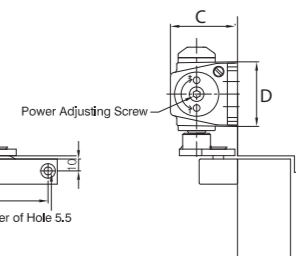
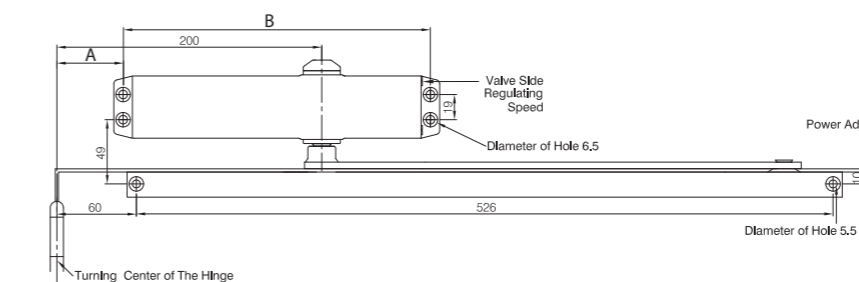

INSTALLATION

Parallel arm installation (with 200-PB bracket)

▼ 83V+200PB

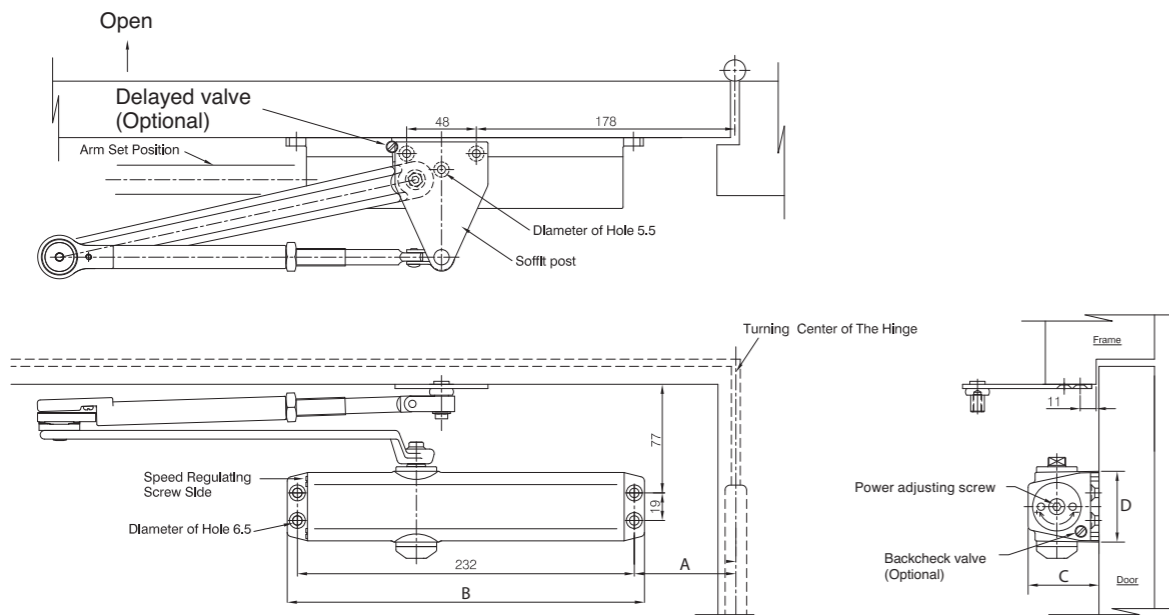

▼ 85V+200PB

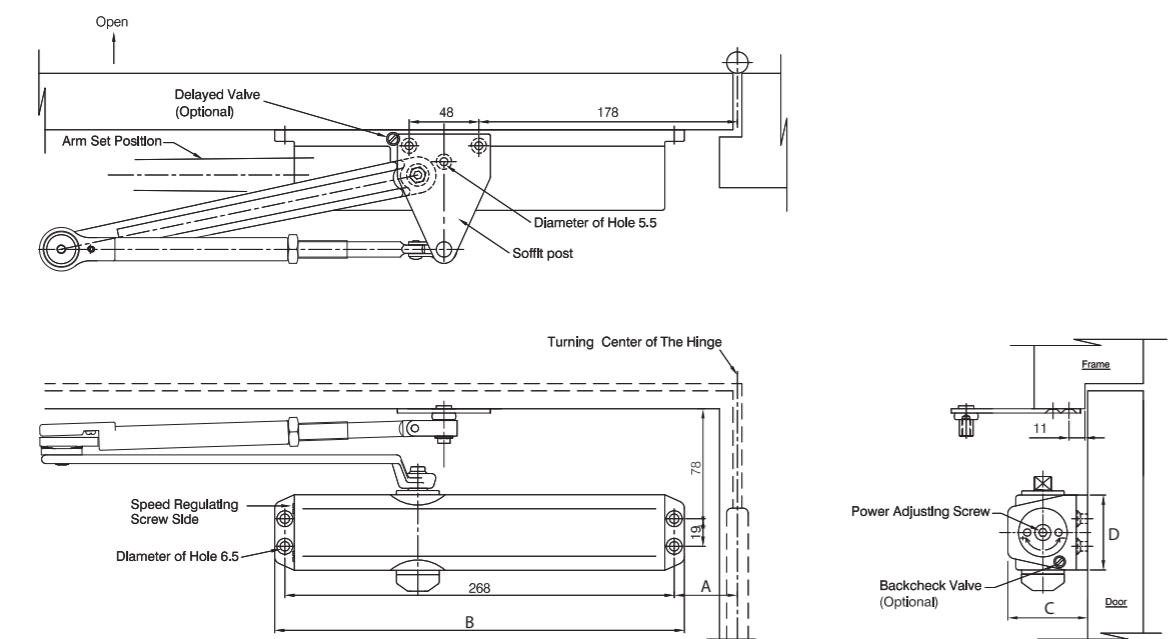

TYPE	A	B	C	D
183V	70	246	49	49
185V	44	282	55	52

(Unit: mm)

INSTALLATION

Parallel arm installation (with 200-PB1 bracket)

▼ 183V+200PB1

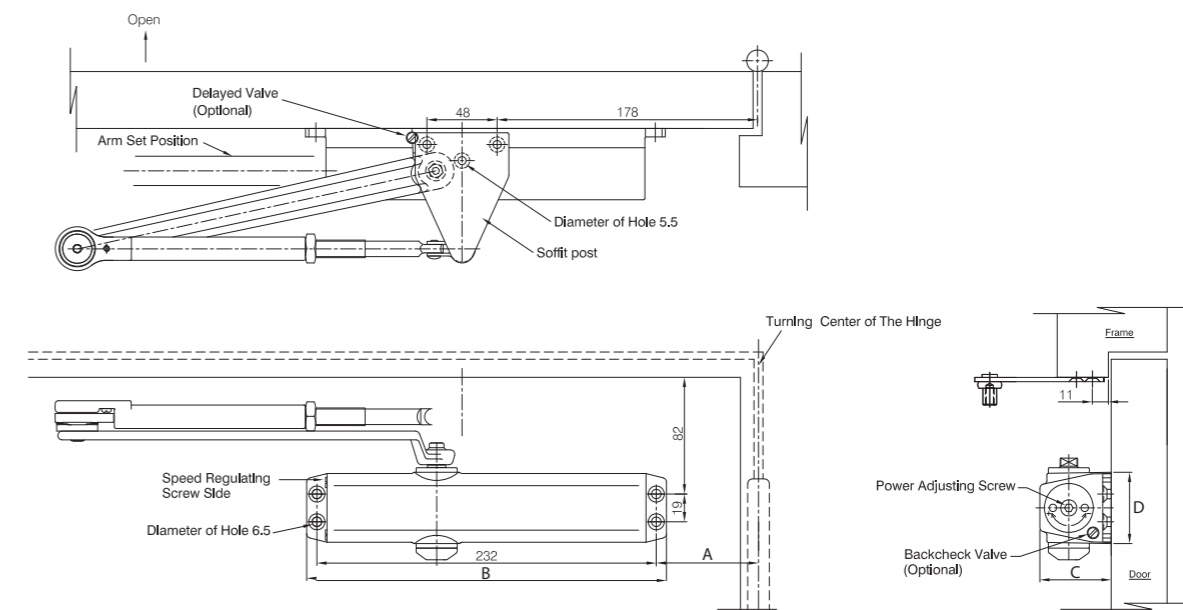

▼ 185V+200PB1

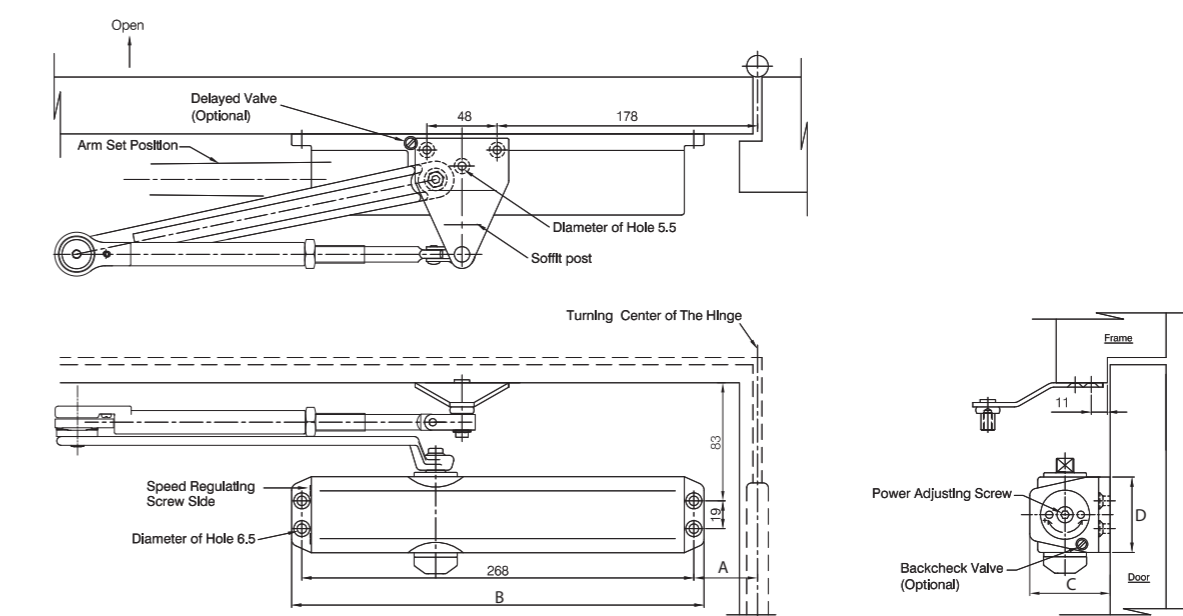

TYPE	A	B	C	D
183V	70	246	49	49
185V	44	282	55	52

(Unit: mm)

INSTALLATION

Parallel arm installation (with 820SPB bracket)

▼ 183V+820SPB

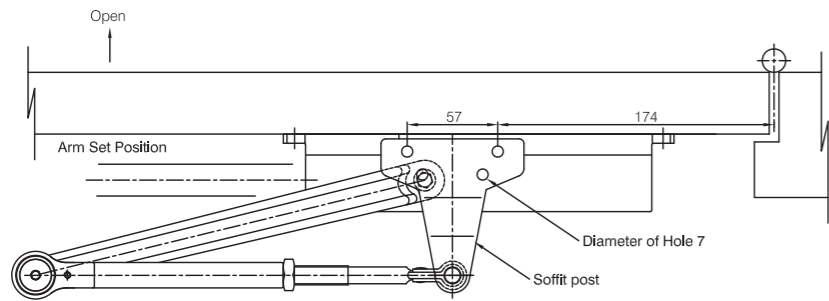

Unit : mm

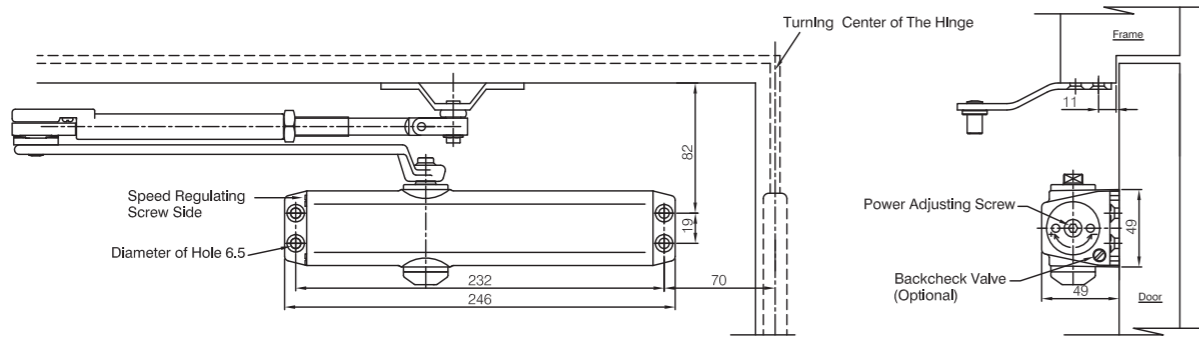

▼ 185V+820SPB

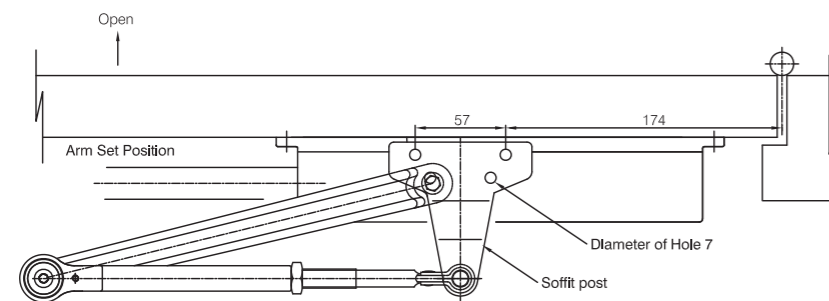

Unit : mm

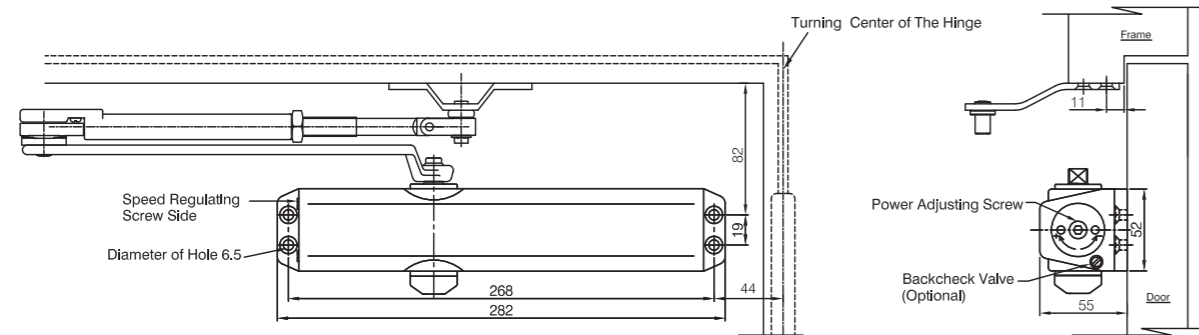

PARTS & ACCESSORIES

PARALLEL PLATE(200-PB)

50%

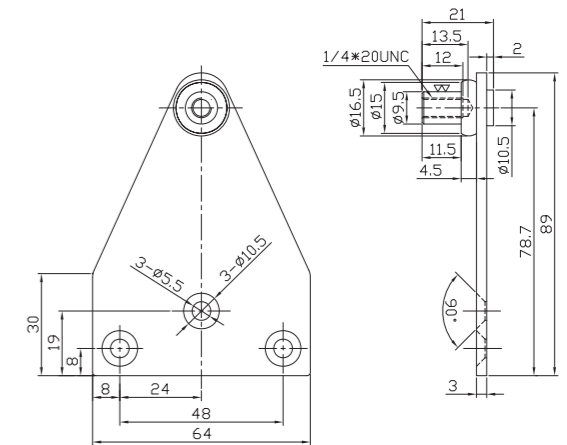
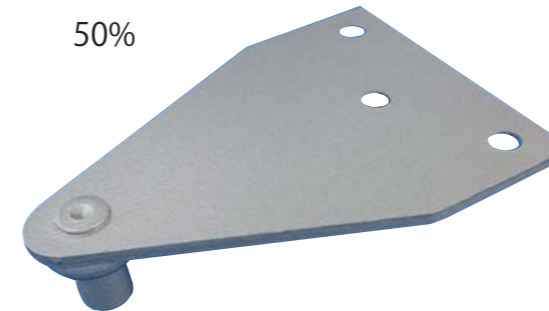

STEPPED PARALLEL PLATE (200PB-1)

50%

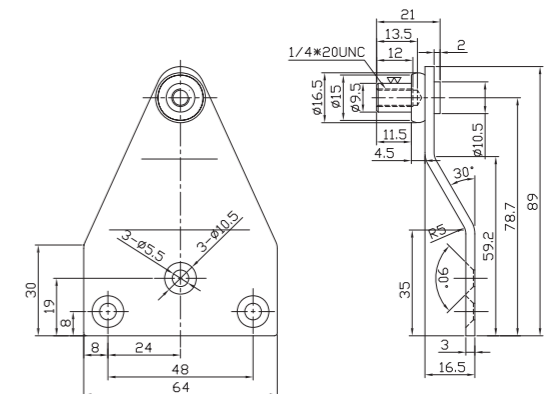

STEPPED PARALLEL PLATE (820SPB)

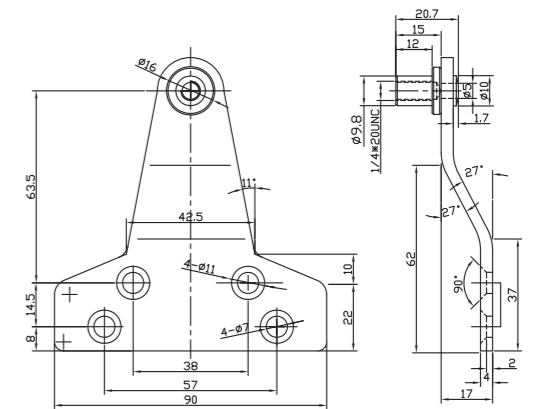
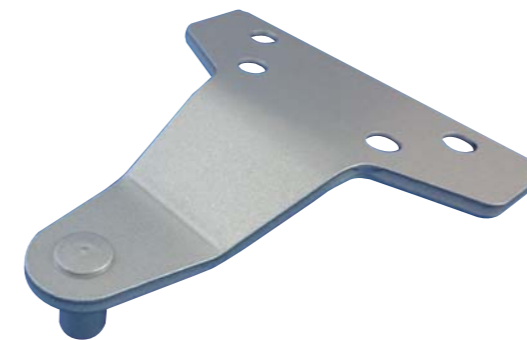

L-SHAPED BRACKET(200-PB-NHN)

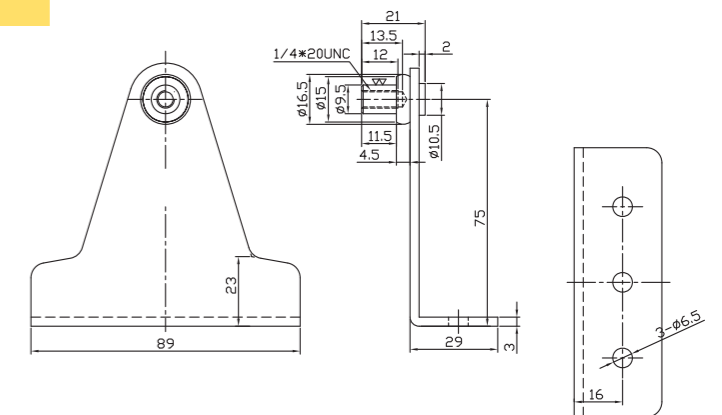
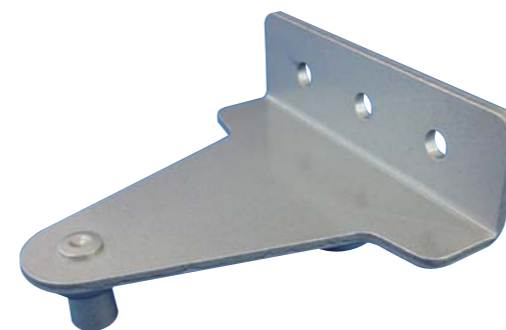

PARTS & ACCESSORIES

CONVERSION BRACKET (100-PB)

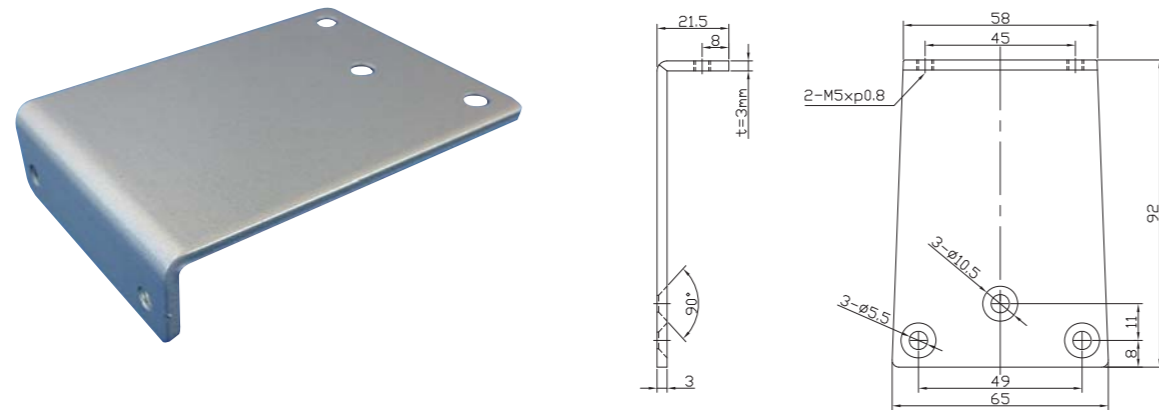

PARALLEL PLATE(200-PB)

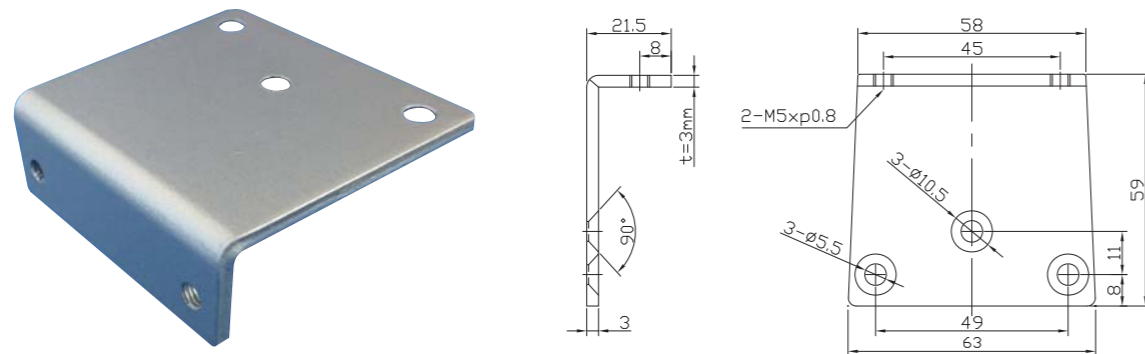

DROP PLATE (83V/85V-FP2)

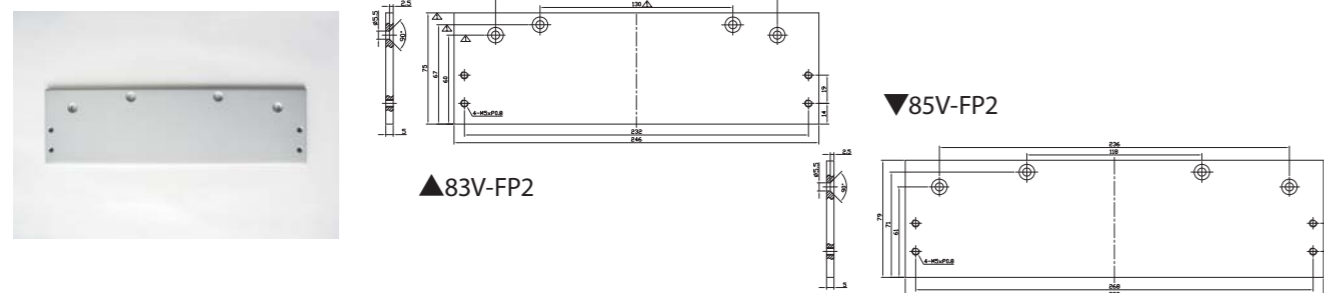

MOUNTING PLATE (83V/85V-FP4)

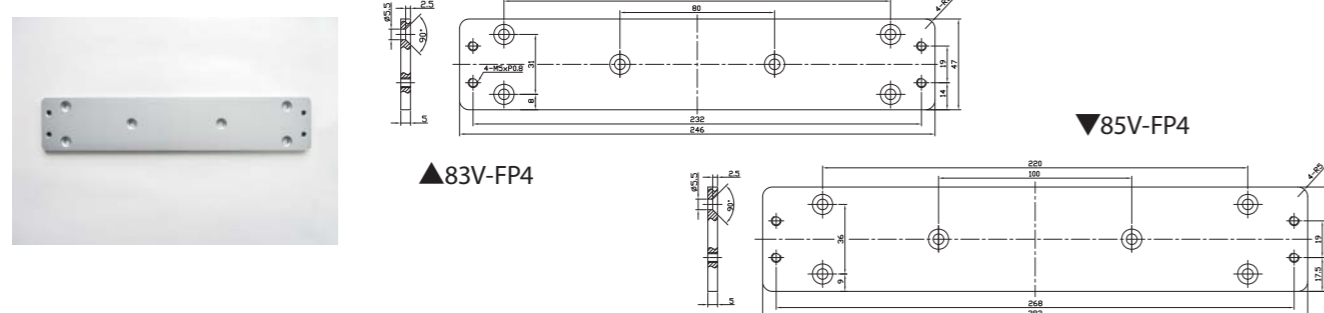

ACCESSORIES

HOLD OPEN ARM

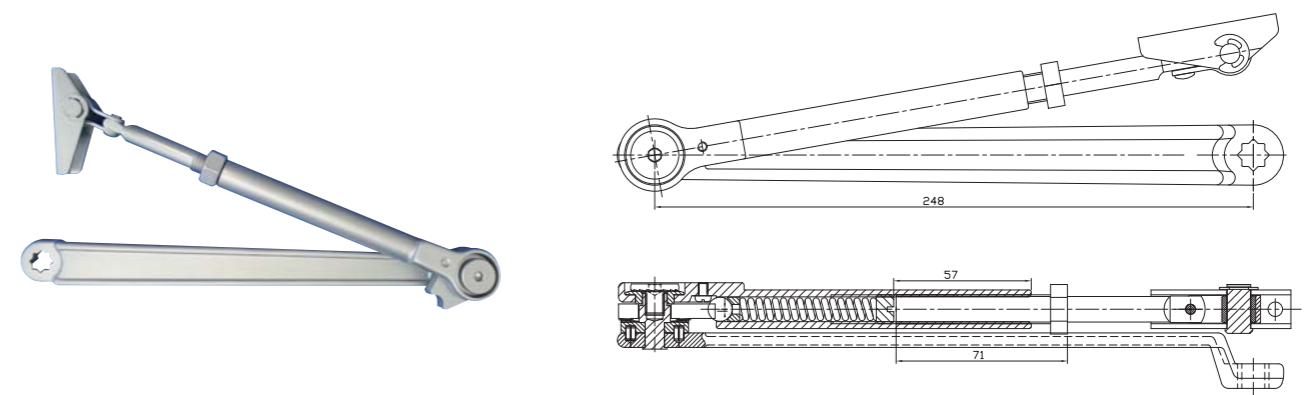

COUPLING



COVER

