



ATLANTA INDUSTRIES, INC.
est. 1978



Ver. 02 January 2016
www.atlanta.ph



PVC FENCE

Patent application no.: 2-2000-00021

ATLANTA'S

new trend
in fencing

ADVANTAGES

Atlanta Industries Incorporated introduces the Classique PVC Fence systems available for a wide range of commercial, residential and industrial applications.

Made from durable polyvinylchloride (PVC) Classique Fence is durable and long lasting.

This new system is recommended in the Philippines specially for residential and commercial use.

Designed to prevent rust caused by salty air in coastal areas, sulfuric acid near volcanoes and polluted air near high density areas.

Classique will enhance the value of your property because this revolutionary method requires little or no maintenance normally experienced with conventional wood- type or iron fencing.

The panels are easy to install using the notching tool for the locking tab method, or by securing profiles with a retaining screw.



EXTRUDED PVC FENCING PROFILE

Profile Dimensions (Cross Section) Posts	Normal Wall Thickness	Code
4.00" X 4.00"	4.0 mm	PS - 4
Profile Dimensions (Cross Section) Posts	Normal Wall Thickness	Code
1.75" X 1.75"	2.0 mm	RL 175175
Profile Dimensions (Cross Section) Posts	Normal Wall Thickness	Code
.750" X .750"	1.8 mm	PK - 7515

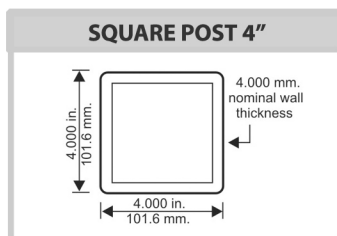

CODE	SIZE
PS - 4	4"x4"x4"

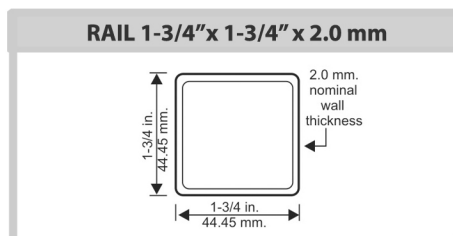

CODE	SIZE
RL - 175175	1-3/4"x1-3/4"x2.0mm

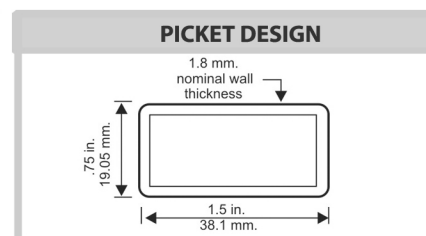

CODE	SIZE
PK - 7515	3/4"x1-1/2"x1.8mm

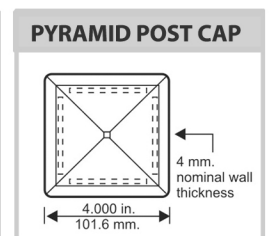

CODE	SIZE
CP - 4	4"



PICKET

Dimensions:

- A. Rail: 1 - 3/4" x 1 - 3/4" x 6'
- B. Post: 4"x 4"x 7'
- C. Picket: 3/4" x 1 - 1/2" x 4"
- D. Pyramid Post Cap: 4" x 4"

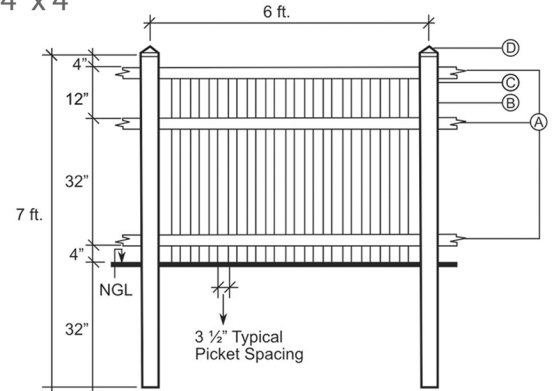

RANCH RAIL

Dimensions:

- A. Rail: 5 - 1/2" x 1 - 1/2" x 8'
- B. Post: 4"x 4"x 7'
- C. Pyramid Post Cap: 4" x 4"

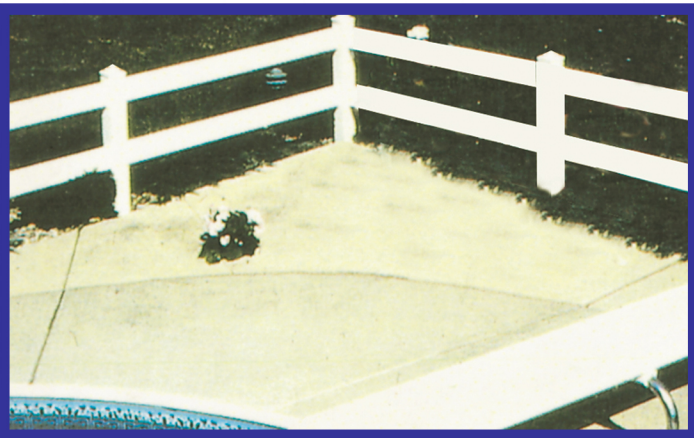
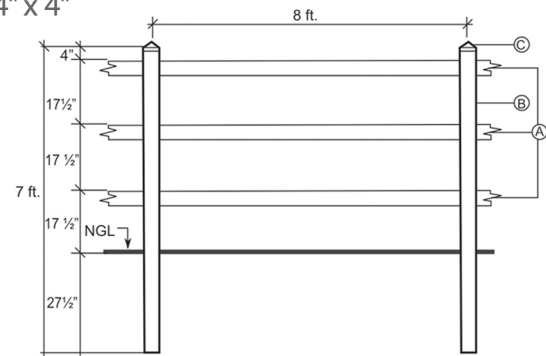

LAWN RAIL

Dimensions:

- A. Rail: 5 - 1/2" x 1 - 1/2" x 8'
- B. Post: 4"x 4"x 6'
- C. Pyramid Post Cap: 4" x 4"

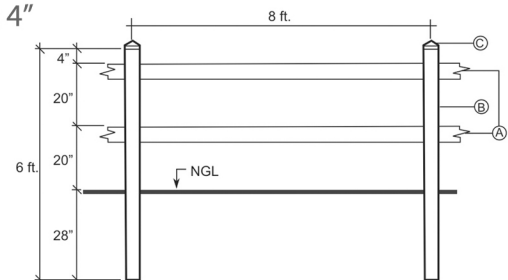



PVC vs WOOD

	PVC (Vinyl) Material	Wood Material
Non-Pro Rated Warranty	Lifetime Warranty	No Warranty
Labor Warranty	Lifetime Warranty	None Included
Projected Life	50+ Years	10-15 Years
Maintenance Free	YES	NO
Graffiti resistance	YES	NO
Termite Free	YES	NO
Fungus & Dry Rot Free	YES	NO
Free of Harmful Chemicals (Arsenic, Lead, Creosote)	YES	NO
Needs Painting	Never	YES
Fade Resistant	YES	NO

Property	Test Method	Value
Specific Gravity (+/-0.02)	ASTM D792	1.46
Using 0.012 specimen: Izod impact ft. lbs./in. notch	ASTM D256	17.0
Tensile Yield Strength, PSI	ASTM D638	6.290
Tensile Modulus, PSI	ASTM D638	430,000
Flexural Yield Strength, PSI	ASTM D790	12,000
Flexural Modulus, PSI	ASTM D790	410,000
DTUL at 264, PSI	ASTM D648	67°C
ASTM Cell Classification	ASTM D4216	1-40131-13-0101

ADVANTAGES:

- Corrosion-free
- Rot-free
- Maintenance-free
- Lightweight (easy to install)
- Cost-efficient

PVC FENCING is available in:



NOTE: Fences are supplied unassembled.

Another quality product of:

ATLANTA INDUSTRIES, INC.

35th Floor Atlanta Centre #31 Annapolis St., Greenhills,
San Juan City, Philippines

Tel. nos.: 723-0781 to 96 / 744-4700 to 05

Fax nos.: 722-8705/744-4703

Website: <http://www.atlanta.ph>

Email: atlanta@atlanta.ph